

Operating Instructions Manuel d'utilisation 取扱説明書

Replacement lamp unit **Commercial Use**

Lampe de remplacement **Utilisation commerciale**

交換用ランプユニット **業務用**

Model No. **ET-LAE12**

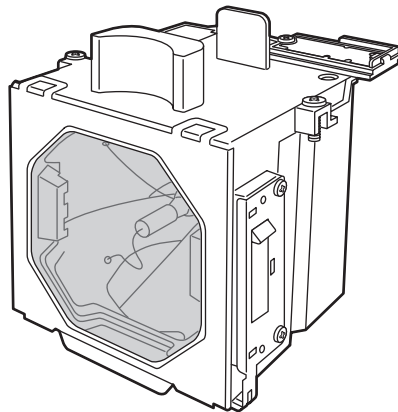

Thank you for purchasing this Panasonic product.

- Before using this product, please read the instructions completely and save this manual for future use.
- Before using this product, be sure to read **“Read this first!”** (➡ page ENGLISH-1).

Nous vous remercions d'avoir choisi ce produit Panasonic.

- Avant d'utiliser ce produit, merci de lire attentivement les instructions et conserver ce manuel afin de pouvoir s'y référer ultérieurement.
- Avant d'utiliser ce produit, assurez-vous de lire **“Avis important concernant la sécurité”** (➡ page FRANÇAIS-1).

このたびは、パナソニック製品をお買い上げいただき、まことにありがとうございます。

- この「取扱説明書」とプロジェクターの「取扱説明書」をよくお読みのうえ、正しく安全に作業を行ってください。そのあと大切に保管してください。
- ご使用前に **“安全上のご注意”** (👁️ 日本語 -1 ページ) を必ずお読みください。

Read this first!

Be sure to follow these instructions.

WARNING:

Do not disassemble the lamp unit.

If the lamp breaks, it could cause injury.

Lamp replacement

The lamp has high internal pressure. If improperly handled, an explosion and severe injury or accidents will result.

- The lamp can easily explode if struck against hard objects or dropped.
- Before replacing the lamp, be sure to disconnect the power plug from the wall outlet. Electric shocks or explosions can result if this is not done.
- When replacing the lamp, turn the power off and allow it to cool for at least 60 minutes before handling it otherwise it can cause burns.

CAUTION:

Do not use the old lamp unit.

If used it could cause lamp explosion.

If the lamp has broken, ventilate the room immediately. Do not touch or bring your face close to the broken pieces.

Failure to observe this will cause the user to absorb the gas which was released when the lamp broke and which contains nearly the same amount of mercury as fluorescent lamps, and the broken pieces will cause injury.

- If you believe that you have absorbed the gas or that the gas has got into your eyes or mouth, seek medical advice immediately.
- Ask your dealer about replacing the lamp unit and check the inside of the projector.

Product information (for Turkey only)

AEEE Yönetmeliğine Uygundur.



WARNING:

TURN OFF THE UV LAMP BEFORE OPENING THE LAMP COVER

NOTICE

For USA only

Hg-LAMP CONTAINS MERCURY, Manage in Accord with Disposal Laws,

See: www.lamprecycle.org or 1-888-411-1996

Replacement of the lamp unit

Notes on the replacement of the lamp unit

- Since the luminous lamp is made of glass, it may burst if dropped or hit with a hard object. Please handle with care.
- A Phillips screwdriver is necessary when replacing the lamp unit.
- When replacing the lamp unit, be sure to hold it by the handle.
- To prevent glass fragments from scattering, hold the lamp unit vertically when replacing it. When the projector is attached to the ceiling, do not work directly under the lamp cover or put your face near it. Remove the lamp cover slowly.
- The lamp contains mercury. When disposing of the used lamp unit, ask your nearest local authorities or dealer about proper disposal of the unit.

Attention

- Use only specified lamp units.
- The product numbers of accessories and separately sold components are subject to change without notice.
- Replacement of all two lamps simultaneously is recommended to ensure a balanced brightness and tint.
- Dispose of the packaging materials properly after unpacking the product.

Replacement procedure

Attention

- When the projector is mounted on the ceiling, do not put your face near the lamp unit.
- Attach the lamp unit securely.
- If the lamp unit is not attached properly, remove it and then attach it again. Forcing the lamp unit in may break the connector.
- The glass surface may be hot. When replacing the lamp unit, be sure to hold it by the handle.

- 1) Check which lamp to replace with the lamp status displayed on the screen, or the lamp indicators <LAMP 1 REPLACE>/<LAMP 2 REPLACE>.

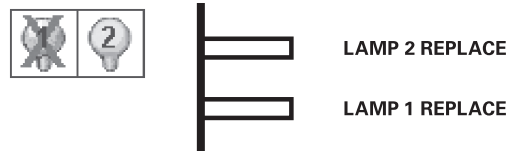

- 2) Press the power <⏻/⏻> button on the control panel or the power <STANDBY> button on the remote control twice.
- 3) When the standby indicator <STANDBY> comes on, press the <○> side of the main power switch to turn off the power, disconnect the power plug from the power outlet, and wait at least 60 minutes, and then check if the lamp unit has cooled down.
- 4) Use a Phillips screwdriver to turn the lamp cover fixing screw until it turns freely, and then open the lamp cover.
 - Pull the lamp cover in the direction of arrow (i) and lift it up in the direction of arrow (ii) to open.

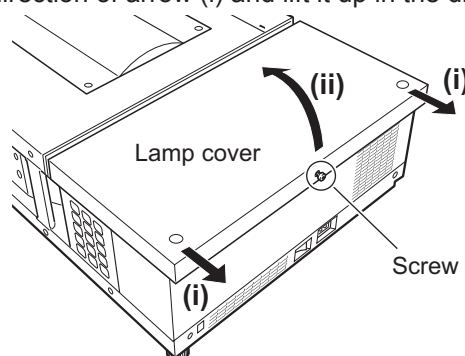

- 5) Use a Phillips screwdriver to turn the lamp unit fixing screws (two screws) until they turn freely, and then holding the handle, slowly pull out the lamp unit from the projector.

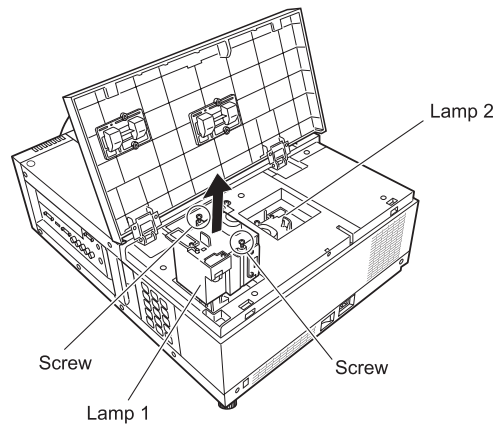

- 6) Insert the new lamp unit taking note of its direction, and use a Phillips screwdriver to firmly tighten the lamp unit fixing screws (two screws).

- Do not smear the glass surface by touching it with your hand.

- 7) Close the lamp cover, and use a Phillips screwdriver to firmly tighten the lamp cover fixing screw.

Note

- When replacing with the new lamp unit (Product No.: ET-LAE12), the projector resets the total usage time of the lamp unit automatically.
- After replacing the lamp unit, be sure to tighten the lamp cover fixing screw. If not, the lamp unit may drop off while projecting.



TURN OFF THE UV LAMP BEFORE OPENING THE LAMP COVER



To prevent glass fragments from scattering, hold the lamp unit vertically when replacing it. When the projector is attached to the ceiling, do not work directly under the lamp cover or put your face near it. Remove the lamp cover slowly.



LAMP NO. : ET-LAE12

Disposal of Old Equipment

Only for European Union and countries with recycling systems



This symbol on the products, packaging, and/or accompanying documents means that used electrical and electronic products must not be mixed with general household waste.

For proper treatment, recovery and recycling of old products, please take them to applicable collection points in accordance with your national legislation.

By disposing of them correctly, you will help to save valuable resources and prevent any potential negative effects on human health and the environment.

For more information about collection and recycling, please contact your local authority.

Penalties may be applicable for incorrect disposal of this waste, in accordance with national legislation.

Environment care information for users in China



This symbol is only valid in China.

Panasonic Projector & Display Corporation

Web Site : <https://docs.connect.panasonic.com/projector>

パナソニック プロジェクター&ディスプレイ株式会社

〒 571-8503 大阪府門真市松葉町 2 番 15 号 電話 ☎ 0120-872-601