

Operating Instructions Manuel d'utilisation 取扱説明書

Replacement filter **Commercial Use**

Filtre de remplacement **Utilisation commerciale**

交換用フィルター **業務用**

Model No. **ET-RFE12**

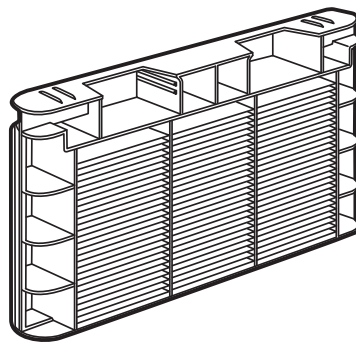

Thank you for purchasing this Panasonic product.

- Before using this product, please read the instructions completely and save this manual for future use.

Nous vous remercions d'avoir choisi ce produit Panasonic.

- Avant toute utilisation de ce produit, merci de lire attentivement les instructions et conserver ce manuel afin de pouvoir s'y référer ultérieurement.

このたびは、パナソニック製品をお買い上げいただき、まことにありがとうございます。

- この「取扱説明書」とプロジェクターの「取扱説明書」をよくお読みのうえ、正しく安全に作業を行ってください。そのあと大切に保管してください。

Replacement of the air filter

- 1) **Turn off the power of the projector, and then unplug the power cord from the outlet.**
 - When turning off the power, make sure to follow the procedures in “Powering off the projector”.
- 2) **Slide the air filter cover.**
 - Pull and slide the air filter cover in the direction shown by the arrow.
 - The top part of the air filter appears.

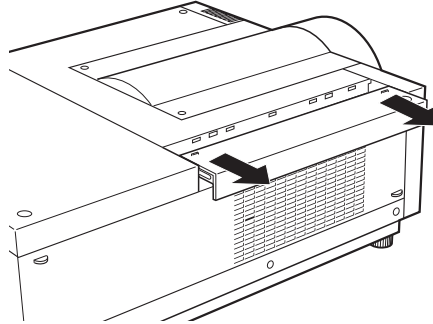

- 3) **Remove the air filter.**
 - Hold the grip of the air filter to pull up.

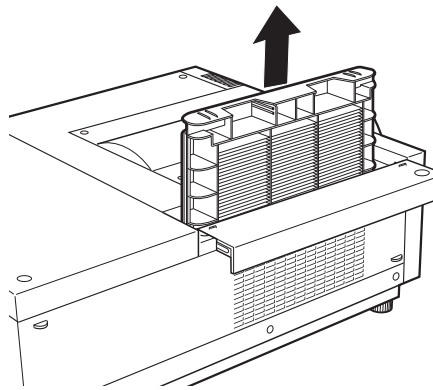

- 4) **Attach a new air filter.**
 - Insert a new air filter with its tabs facing down.
- 5) **Slide the air filter cover to the original position.**
 - Perform Step 2) in the reverse order.
- 6) **Insert the power plug into the outlet to turn on the power, and perform [Filter counter reset].**
 - For details, refer to “Resetting the value of [Filter counter]” (➡ page ENGLISH-2).

Attention

- Before attaching a new air filter, be sure to remove the packing material of the air filter.
- When attaching the unit, make sure that the projector is stable. Perform the replacement in a safe place where the projector will not be damaged even if you drop the air filter.
- After replacing the air filter, reset the filter counter. Otherwise, the power of the projector may be turned off for safety.
- Dispose of the packaging materials properly after unpacking the product.

Resetting the value of [Filter counter]

After replacing the filter, be sure to reset the counter.

- 1) **Select [Setting] from the main menu on the menu screen.**
- 2) **Press the <ENTER> button.**
 - The sub menu is displayed.
- 3) **Press ▲▼ to select [Filter counter].**
- 4) **Press the <ENTER> button.**
 - The sub menu 2 is displayed.
- 5) **Press ▲▼ to select [Filter counter reset].**
- 6) **Press the <ENTER> button.**
 - A screen for confirming whether to reset is displayed.
- 7) **Select [Yes], and press the <ENTER> button.**
 - The confirmation screen is displayed.
- 8) **Select [Yes], and press the <ENTER> button.**

Note

- Reset only after replacing the filter.
- When reset, the display of [Filter warning] disappears.

Disposal of Old Equipment

Only for European Union and countries with recycling systems



This symbol on the products, packaging, and/or accompanying documents means that used electrical and electronic products must not be mixed with general household waste. For proper treatment, recovery and recycling of old products, please take them to applicable collection points in accordance with your national legislation.



By disposing of them correctly, you will help to save valuable resources and prevent any potential negative effects on human health and the environment.

For more information about collection and recycling, please contact your local authority.

Penalties may be applicable for incorrect disposal of this waste, in accordance with national legislation.

Environment care information for users in China



This symbol is only valid in China.

Product information (for Turkey only)

AEEE Yönetmeliğine Uygundur

Panasonic Projector & Display Corporation

Web Site : <https://docs.connect.panasonic.com/projector>

パナソニック プロジェクター&ディスプレイ株式会社

〒571-8503 大阪府門真市松葉町2番15号 電話 ☎0120-872-601